

Aerodynamic Loss Measurements in a Linear Cascade with Film Cooling Injection

H. Reiss, A. Böls

Swiss Federal Institute of Technology
Lausanne, Switzerland

ABSTRACT

Film cooling injection is widely applied because of the clear advantages for the thermal design of turbomachinery, as it contributes to achieve the high operating conditions of modern gas turbines, and to meet the requirements for reliability and life cycles. The film cooling injection, however, interacts with the main flow and is susceptible to have an influence on the aerodynamic performance of the cooled components, and through that may cause a penalty on the overall efficiency of the gas turbine. For an overall evaluation of the quality of film cooling schemes, which is attempted in this work, it is therefore important to consider both aspects – thermal and aerodynamic ones.

This paper deals with the aerodynamic effect of film cooling. It is subdivided into five parts: First, a brief introduction about the role of film cooling on loss is given. The definitions for the evaluation of loss coefficients used in the present study are given next, followed by the some details about the experimental setup and the measurement equipment. Subsequently, the problem of the evaluation of the coolant distribution in the downstream plane is discussed, and its role for the correct determination of aerodynamic losses is considered. Finally, the results from the systematic investigation on the four different airfoil models with various film injection configurations is presented and discussed.– these experiments were performed at near-engine main flow conditions, realistic coolant-to-mainflow density ratios, and blowing regimes.

NOMENCLATURE

C	[-],[%]	mass-concentration of coolant gas in air
c_p	[J/kgK]	specific heat at constant pressure
DR	[-]	coolant-to-gas density ratio ρ_c/ρ_g
h	[kJ/kg/K]	enthalpy
l_1, l_2, l_3	[m]	spanwise extent of coolant concentration profile
\dot{m}	[kg/s]	mass flow rate
\dot{m}_c / \dot{m}_g	[%]	specific coolant mass flow rate
M	[-]	Mach number $u/(\kappa RT)^{0.5}$
p	[mbar]	pressure
R	[J/kg/K]	ideal gas constant
Re_{2L}	[-]	cascade exit Reynolds number $(u_2 L)/\nu$
s	[m]	surface distance from geometrical leading edge
T	[°C], [K]	temperature
Tu	[%]	turbulence intensity
x, y, z	[m]	channel coordinates

β_1, β_2	[°]	cascade in- and outflow angle
ζ	[-]	loss coefficient

SUBSCRIPTS

c	coolant gas
g	main stream gas
r	recovery
s	static conditions, surface
t	total conditions

INTRODUCTION

An extensive review of loss mechanisms in turbomachinery was given by Denton (1993), or more recently by Lakshminarayana (1996). As far as the role of cooling injection on loss is concerned, two types of mechanisms exist: unfavorable ones that may reduce the aerodynamic performance, such as viscous dissipation due to mixing of injection, or possible changes of boundary layer transition. In contrast, favorable effects can be expected from adding additional energy to the flow through coolant injection. The latter effect comes into play especially with strong injection. Conclusions concerning the effect of cooling on loss depend very much on the definition of loss chosen – which is not consistent throughout the body of literature on loss.

Kollen and Koschel (1985) considered film cooling in an annular cascade. They reported that cooling may increase or decrease the cascade loss, depending on the injection location. Leading edge injection reduced loss, whereas trailing edge injection increased it. Drost and Böls (1999) showed loss measurements on a multi-row film-cooled vane and reported strong increase of loss due to film injection, and reduced turning of the flow. They attributed this mainly to thickening of the boundary layer mainly on the suction side, and to the introduction of additional pitchwise velocity components due to injection. Day et al. (1997) presented aerodynamic loss measurements on film cooled airfoils with cylindrical holes, at engine-near Mach and Reynolds numbers and reported a small reduction of efficiency which they explained with a slight thickening of the boundary layer. Kapteijn et al. (1996) have investigated losses downstream of annular cascade featuring trailing edge injection. Sieverding et al. (1996) carried out a similar study in an annular rig. They reported that the exit flowfield is significantly influenced by the specific slot configuration.

Presented at the

15th Bi-annual Symposium on Measurement Techniques in Transonic and Supersonic Flow in Cascades and Turbomachines

University of Florence, 21-22 Sept. 2000

DEFINITIONS

The losses without consideration of coolant injection are characterized by a dimensionless number usually referred to as *primary loss coefficient* ζ_{pr} , which is defined as

$$\zeta_{pr} = 1 - \frac{\text{actual kinetic energy}}{\text{isentropic kinetic energy}|_g} \quad (1)$$

For practical applications, when loss coefficient is to be determined based on experimental data from a pneumatic probe measurements, ζ_{pr} can be expressed in terms of static and total pressures as

$$\zeta_{pr} = \frac{\left(\frac{p_{s2}}{p_{t2}}\right)^{\frac{k-1}{k}} - \left(\frac{p_{s2}}{p_{t1}}\right)^{\frac{k-1}{k}}}{1 - \left(\frac{p_{s2}}{p_{t2}}\right)^{\frac{k-1}{k}}} \quad (2)$$

The definition of the primary loss coefficient does not take the energy of the injected coolant into account, and is therefore not suitable to fully evaluate the aerodynamic effect of film cooling. More adequate is the *thermodynamic loss coefficient* ζ_{th} , defined as

$$\zeta_{th} = 1 - \frac{\text{actual kinetic energy}|_{mix}}{\text{isentropic kinetic energy}|_c + \text{isentropic kinetic energy}|_g} \quad (3)$$

Again, for practical application, expressed in terms of measurable quantities, pressures, yields

$$\zeta_{th} = 1 - \frac{(1+C) \cdot h_{t,mix} \left(\frac{p_{s2}}{p_{t2}}\right)^{\frac{k-1}{k}}}{h_{t,g} \left(1 - \left(\frac{p_{s2}}{p_{t1}}\right)^{\frac{k-1}{k}}\right) + C \cdot h_{t,c} \left(1 - \left(\frac{p_{s2}}{p_{t,c}}\right)^{\frac{k-1}{k}}\right)} \quad (4)$$

This equation contains the local coolant mass concentration:

$$C = \frac{\dot{m}_c}{\dot{m}_g} \quad (5)$$

which needs to be known to properly determine the thermodynamic loss. The total enthalpy terms of the main flow $h_{t,g}$, the coolant gas $h_{t,c}$, and the gas mixture $h_{t,mix}$, can be evaluated according to

$$\begin{aligned} h_{t,g} &= c_{pg} \cdot T_{t,g} \\ h_{t,c} &= c_{pc} \cdot T_{t,c} \\ h_{t,mix} &= c_{pmix} \cdot T_{t,mix} \end{aligned} \quad (6)$$

The total temperatures of both gas and coolant are readily available: they are directly measured with total temperature probes upstream of the test section for $T_{t,g}$, and in coolant supply plenum inside the airfoil model for $T_{t,c}$. However, the total temperature of the gas mixture is more difficult to assess experimentally. It could be measured with a specially designed total temperature probe at the cascade exit, but this was not available for the present work. Instead, it can be calculated as a mixing temperature of the coolant

and the main flow gas. Supposing ideal gases and assume constant specific heat for both species, this mixing temperature can be calculated as:

$$T_{t,mix} = \frac{c_{pg} \cdot T_{t,g} + C \cdot c_{pc} \cdot T_{t,c}}{(1+C) \cdot c_{pmix}} \quad (7)$$

containing the specific heat of the mixture

$$c_{pmix} = \frac{c_{pg} + C \cdot c_{pc}}{1+C} \quad (8)$$

Once the mass concentration is known at a given point in the flowfield, the exact total temperature, and therefore the thermodynamic loss can be calculated. Variation of the coolant concentration has an influence on the thermodynamic loss coefficient through two effects: the mixing total temperature is a function of concentration, and so are the actual mass flow.

Usually the concentration measurements are not available. But it can be approximated by assuming that the concentration profile is similar to the one of the *normalized total pressure loss*, $(1-pt_2/pt_1)$ in the downstream plane according to Osnaghi et al. (1997),

$$\frac{C(x)}{C_{max}} = \frac{(p_{t1} - p_{t2}(x))}{(p_{t1} - p_{t2})_{max}} \quad (9)$$

The value of C_{max} is determined such that the integration of the coolant mass flow over the entire downstream plane will match exactly the overall quantity of coolant gas supplied to the airfoil model (this is usually done iteratively).

The underlying assumption of equation (9) is not very accurate, since the actual coolant distribution, or the location and number of injection stations of the cooling scheme are not taken into account. The approach is however often justified with the fact that the typical concentration values are relatively small over the most part of the passage, and thus errors are negligible.

At a concentration of zero, the two expressions for ζ_{pr} and ζ_{th} are identical. The thermodynamic loss is expected to be higher than the primary loss, and as the coolant concentration increases, one would expect rising values of ζ_{th} . However, a closer look at the loss definition shows that ζ_{th} contains additional concentration-terms in both nominator and denominator. A dimension analysis yields that the actual tendency of ζ_{th} , when the quantity of coolant is increased, depends on the total enthalpies of the gas mixture and of the coolant, which in turn is a function of coolant total conditions and properties. In other words, low enthalpy injection can even decrease the thermodynamic loss.

It is often convenient to use mass-averaged quantities, for example when comparing overall losses between different airfoil models, or injection conditions. For completeness, equation (10) shows the formulation employed for mass-averaging, with an arbitrary quantity ξ . The bounds of the integration (or summation, respectively) are chosen to cover a pitchwise distance corresponding one airfoil spacing:

$$\bar{\xi} = \frac{\int_{x_{min}}^{x_{max}} \xi \cdot \dot{m}(x) dx}{\int_{x_{min}}^{x_{max}} \dot{m}(x) dx} = \frac{\sum_{i=1}^n \xi_i \cdot \dot{m}_i \cdot dx_i}{\sum_{i=1}^n \dot{m}_i \cdot dx_i} \quad (10)$$

LOSS-METHODOLOGY BASED ON 5-HOLE PNEUMATIC PROBE

Aerodynamic losses can be determined experimentally with various measurement techniques. Non-intrusive techniques may be preferred, as for example the laser-2-focus method (L2F), or particle image velocimetry (PIV). In many cases, such non-intrusive techniques are not applicable due to limitations of the test facilities (optical access, window quality, shortcomings of particle seeding etc.) and frequently aerodynamic probes are used for the evaluation of loss profiles. The next figure shows a view of the linear cascade used in this study, including the aerodynamic probe situated in the downstream plane.

The linear cascade consists of 5 airfoil models with bypass vanes and tailboards. Straight endwalls were used for the present study, and the channel width was 99mm. The airfoil profile is a simplified 2-d version of a modern inlet nozzle guide vane, with a nominal turning of 72°. The cascade is supplied by a continuously running air source (a 4-stage radial compressor) and the nominal flow conditions were in the high subsonic range (peak profile Mach number of 0.95 on the suction side). The center airfoil is exchangeable, and various film configurations can be inserted (see Table 1). The probe head is located about 0.6 chord lengths downstream of the trailing edge, details of the probe head are given in Figure 2. The probe head is mounted on a double-bended shaft which allows to perform full traverses over the almost two airfoil spacings in pitchwise direction despite the given limitations due to the obstruction by the tailboard 1, or the access window.

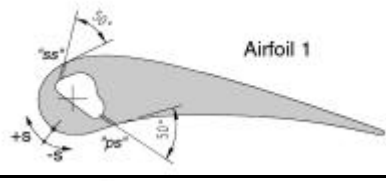
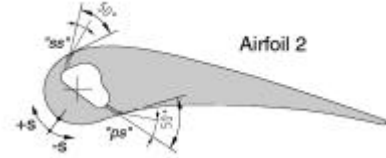
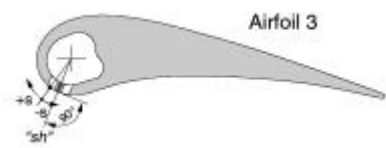
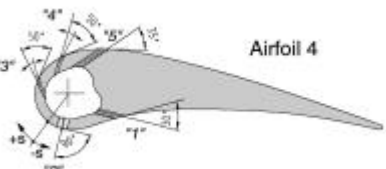
Airfoil Configuration	Features
	<u>Pressure Side:</u> Cylindrical Holes <u>Suction Side:</u> Cylindrical Holes
	<u>Pressure Side:</u> Shaped Holes <u>Suction Side:</u> Shaped Holes
	<u>Leading Edge:</u> Showerhead with Slots
	Full Coverage with 5 Rows and Various Hole Shapes

Table 1 – Airfoil Configurations with Film Cooling Injection

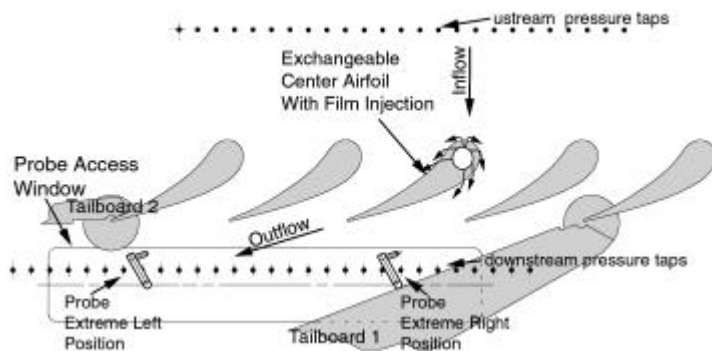


Figure 1 – Linear Cascade Setup with Probe Traversing Mechanism in the Downstream Plane

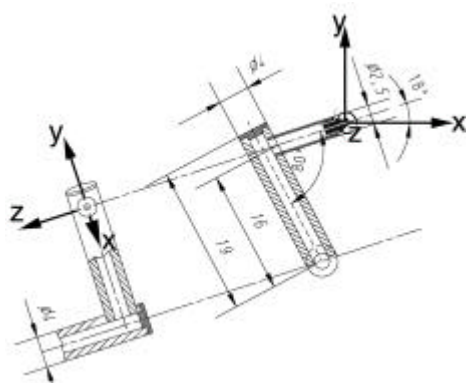


Figure 2 – Detail of the Probe Head

A known problem with aerodynamic probe measurements is the fact that the presence of the probe in the channel might introduce an error by modifying the flow field. This effect is particularly disturbing in the range of flow conditions present at cascade exit, which is in the high sub-sonic range. At such Mach numbers the flow field is very sensitive to additional obstacles or blockage. Clear advantages of this technique were that the experimental system was relatively easy to control, and a calibrated 5-hole probe with traversing mechanism was available. The probe head had a diameter of 3 mm, and was located at a distance of 0.6L from trailing edge, measured in outflow direction.

In order to validate the experimental approach the influence of the probe had been checked at the nominal operating point of the cascade for which all subsequent measurements with cooling were performed. Figure 3, on top, left, shows detailed Mach number distribution gathered in the downstream plane over approximately 2 pitches in lateral direction, and a spanwise range from 35 to 65 %. Closer to the endwalls the effect was not considered, as the “cooled” test program consisted of mid-span traverses only. The wakes of the center and left neighboring airfoils are clearly detected by zones of minimum flow velocity. A considerable spanwise gradient of the Mach number can be noticed, being certainly caused by a flow blockage effect due to the probe itself. (For illustration: The probe is actually inserted through from the front, in the view of Figure 3). The further the shaft penetrates into the channel, the lower the Mach number. The corresponding mid-span distribution is shown below, the variation over the middle 30% is marked as error bars. As can be expected, the probe is most remarkable in zones of high velocity (between the wakes), whereas right in the wake, the influence is very weak.

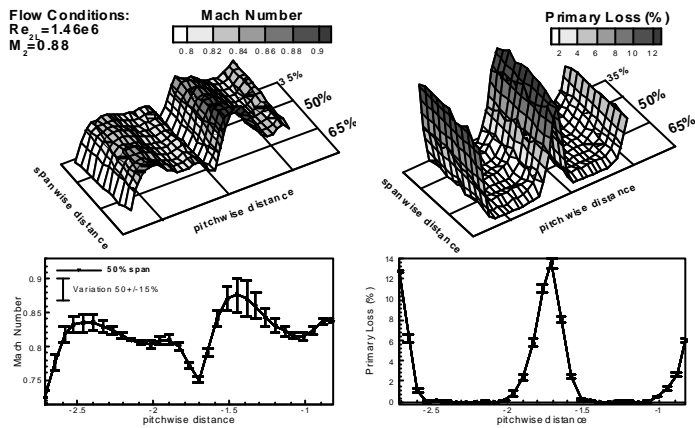


Figure 3—Mach Number and Primary Loss Distributions in Downstream Plane – Influence of the Probe Shaft

Based on this observation, it must be stated that simple calculation of loss profiles based on the local velocities will not be correct. During the measurement campaign, it was seen that the choking due to the probe shaft not only influences local Mach numbers in the downstream plane, but also shifts upwards the pressure levels throughout the passages, as well as upstream of the cascade. More specifically, the total pressure upstream also increased by some 5-10 mbar with the probe present. Consequently, using the nominal total pressure for the determination of losses would be wrong. Instead the ‘corrected’ total pressure needs to be taken into account at every given point in downstream plane.

On the right of Figure 3, primary loss is presented for that same flow condition. At each point, the loss coefficient was computed according to equation (2) with the ‘corrected’ p_t , i.e. measured with the 5-hole probe in its respective position. The spanwise variations are small over the entire passage. This shows that, even if the probe influences the flow field by causing ‘false’ gradients in the velocity profile, the influence of the probe shaft can at least partly be accounted for. The residual error could not be assessed with the current experimental setup, but is estimated very small and will be neglected in the following.

Based on this finding, the automated measurement system was adapted to yield the following procedure for data acquisition: For each data point, the 5-hole probe was placed first; then the total pressure reading was taken (insertion of the total pressure probe upstream, acquisition of p_t , retrieving probe again), and last the pressure values from the 5-hole probe were acquired. An inconvenience of this procedure was that testing time per data point was increased by a factor 2, compared to simple traverses with probe readings only. This had some implications on the measurement program, because in the case of probe traverses with foreign gas injection, the coolant needs to be supplied over the entire duration of the traverse. This caused problems with the capacity of the coolant supply system, which is based on a coolant reservoir, and can provide a constant mass flow only over a limited time. Therefore, the traverses with cooling consisted of a relatively small number of data points (30-50) in the midspan plane.

Solid Blade Loss

Full traverses with 300 data points over entire downstream plane were acquired with a solid blade installed (without cooling holes), at nominal flow conditions. The contour plots on top of Figure 4 show the detailed primary loss distribution, and midspan values of loss and pitchwise exit angle are depicted below.

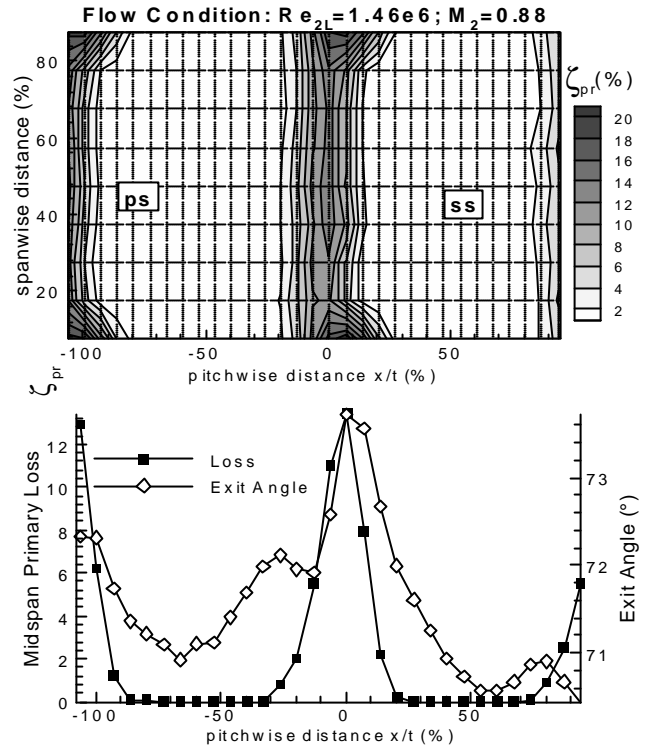


Figure 4 – Solid Blade Primary Losses for Nominal and Lower Cascade Operating Point ($Re_{2L}=1.46e6$, and $Re_{2L}=1.01e6$)

The loss distribution is quite homogeneous over the center portion of the channel, and the profiles are remarkably symmetrical with respect to the channel center. Knowing from other aerodynamic measurements that – except for the near-wall region - the flow field is purely 2-dimensional, this confirms the validity of the measurement procedure. In proximity of the endwalls, the typical effect of secondary flow can be seen towards the suction side. The differences between the two flow conditions are very small. The wake core is slightly broader and higher at nominal flow conditions. Exit flow angles at midspan show approximately the same behavior. An average flow angle of approximately 72° results. Further measurements (not presented here) showed that for this airfoil profile the downstream flowfield is fairly constant over a wide range of flow conditions (in terms of losses and cascade turning).

ASSESSMENT OF COOLANT CONCENTRATION PROFILES IN DOWNSTREAM PLANE

The role of the local coolant concentration for the determination of thermodynamic losses was briefly mentioned above. It was also described how the concentration is usually approximated. Some further consideration on this issue are added here:

When approximating the coolant distribution in the downstream plane according to equation (9), an assumption needs to be made on the spanwise distribution, particularly if – as in the present case – the film rows cover only a part of the airfoil span. Three different possibilities are sketched in Figure 5: There is the ‘true’ spanwise distribution marked as ‘1’, which is typically flat in the center and fading out towards the sidewalls due to dilution/diffusion. This can be assumed to correspond to reality, even in a 2-dimensional flow field. ‘2’ assumes simple rectangular distribution with a constant value equal to the true peak value, and with a spanwise width of l_2 which lies somewhere between l_1 and

l₃. Profile “3” simply distributes the coolant gas homogeneously over the injection width and neglects lateral diffusion effects.

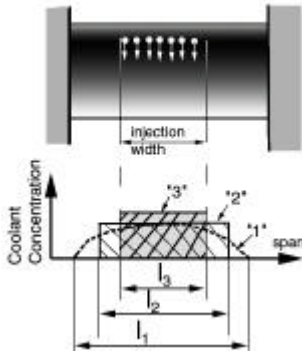


Figure 5 – Spanwise Distribution of Coolant Gas – Different Models for Concentration Profiles

If no concentration measurements are available, profile “3” may seem the most straight forward. However, it is clear that the peak concentration will be overestimated, the actual values is a function of the real lateral spread of the coolant.

During the present study, a gas simple sampling device was assembled which allowed to acquire the true CO₂ concentration profiles with the 5-hole probe, necessitating no further hardware modification, only small changes of the measurement procedure. This new possibility allowed to determine the lateral coolant distribution, and hence to check the correctness of the commonly used assumption. Typically, the width of the rectangular profile “2” was determined to be 1.2 to 1.5 times the injection width, as shown in the sketch. The exact value depended on actual cooling configuration and injection rate. Cooling configurations with ‘early’ injection (close to leading edge, such as airfoil 3), and strong compound angle orientation had higher values, which seems reasonable since these features should promote lateral diffusion.

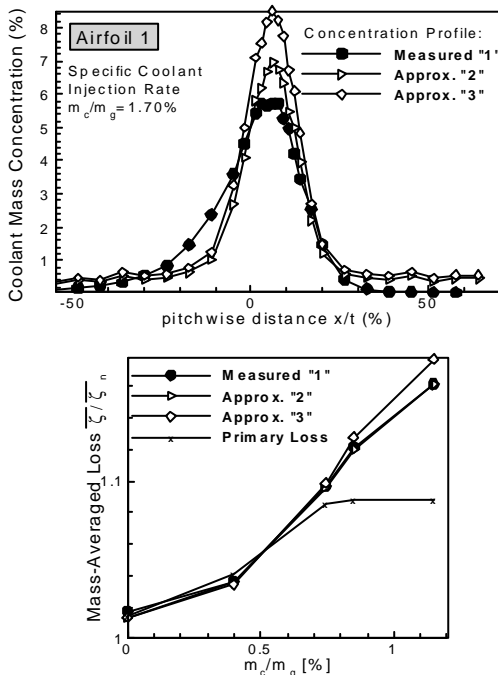


Figure 6 – Pitchwise Coolant Concentration Profiles and Resulting Thermodynamic Loss Coefficients

In Figure 6 the problem of choosing the right lateral concentration distribution is illustrated with sample results that were obtained on airfoil 1 with CO₂-injection ($m_c/m_a=1.7\%$, both cooling rows open). The measured pitchwise concentration profile for this case (solid symbols) are superposed with the approximated profiles “2” and “3”. It is apparent that the shape of the approximated profiles is different from the real one, which is broader and slightly unsymmetrical with respect to the wake core. Assumption “3” overestimates the peak concentration by 40%.

The graph on the bottom of Figure 6 shows the normalized, mass-averaged thermodynamic losses computed on basis of the three concentration profiles “1”, “2” and “3”, as a function of the injected coolant quantity. For comparison reasons, also the primary loss is added. For higher injection rates, the primary loss is indeed considerably lower than the thermodynamic loss, as it was mentioned when introducing the different loss parameters earlier in this paper.

The curves obtained with the measured profile “1” and the approximation “2” practically coincide. This means that approximating the relative shape of the concentration profile has only a negligible effect on the thermodynamic loss.

Approximation “3”, however, yields considerably higher mass-averaged loss ζ_{th}/ζ_n , compared to the measured profile. The discrepancy is getting stronger when increasing the mass flow rate. In other words, overestimating the overall concentration level, by supposing “straight” coolant propagation through the wind tunnel, introduces a noticeable error. The dependency of thermodynamic loss on the injection rate is in that case too strong. The result is by 15% too high, compared to the ‘exact’ value. Therefore the lateral spread should be accounted for, if possible.

It can be concluded that for the correct calculation of the thermodynamic loss with film cooling, it is necessary to employ the correct ‘overall’ level of coolant concentrations, whereas poorly estimated shapes of concentration profiles in pitchwise direction have only negligible effect. If measurements are available, the correct profile can be employed, if not, the approximation “2” should be used.

This finding is checked with a comparison of peak thermodynamic loss, which is much more sensitive to concentration errors than the mass-averaged values. Figure 7 shows results for all 4 cooled airfoil models, based on the measured profile “1”, and approximation “2”. It was shown that the differences are generally small, except for very high blowing conditions.

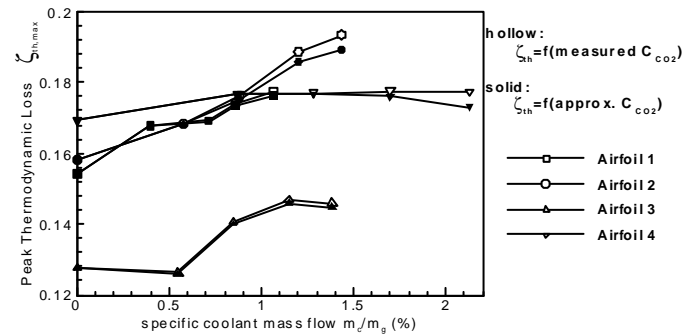


Figure 7 – Peak Thermodynamic Loss Coefficients : Comparison of Evaluation Based on Measured and Approximated Coolant Gas Concentration

After these preliminary considerations about the assessment of coolant gas concentrations, and its role for the correct determination of losses with film injection, detailed concentration results are presented in Figure 8 for all airfoil models. The data was taken at midspan over a distance of approximately one pitch.

The concentration readings needed to be taken manually which was quite time-consuming, so for this systematic investigation the number of data points per traverse was limited to about 30, with refined spacing in the wake region. The results are shown in the form of mass concentration of CO₂ in Air.

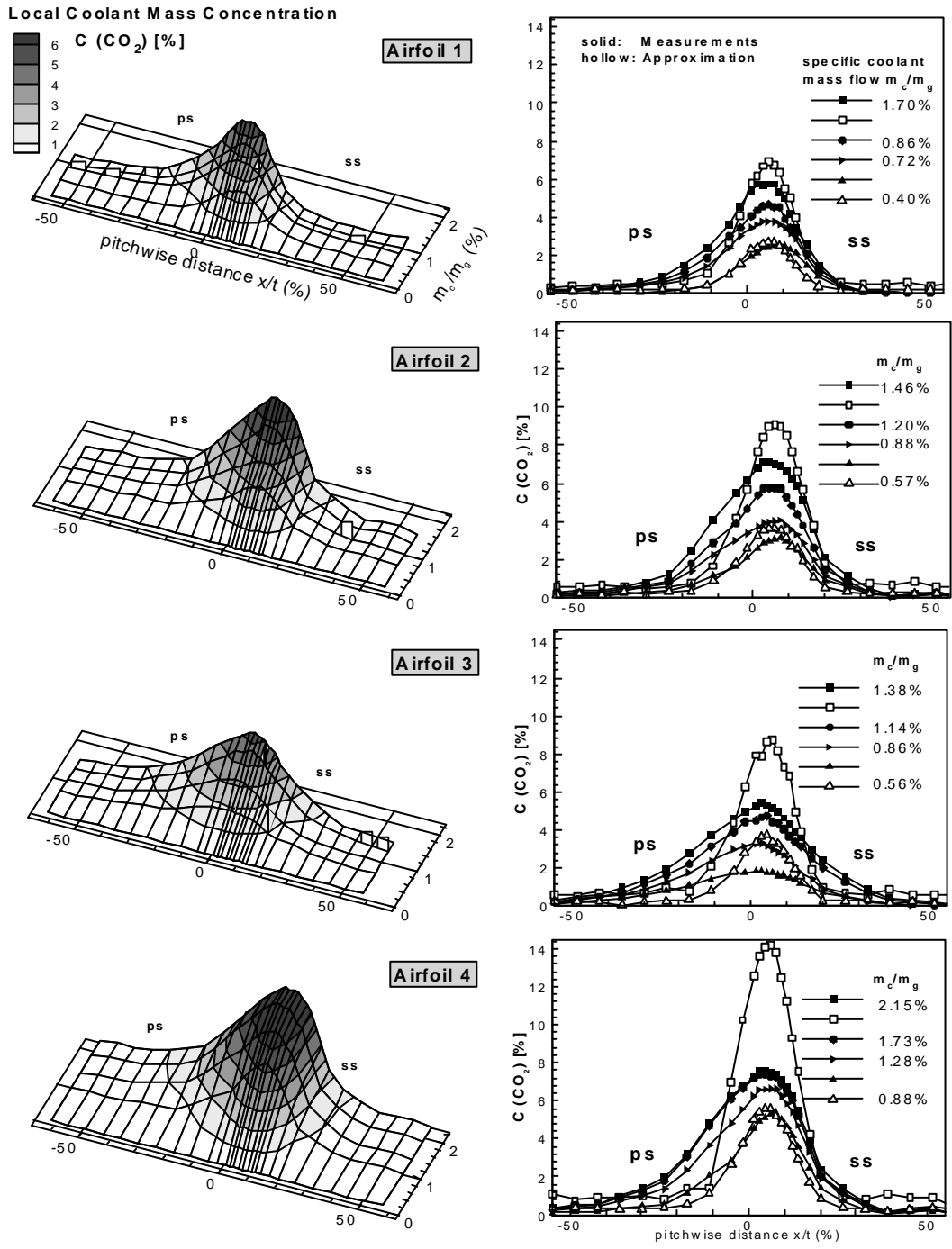


Figure 8 – Results of CO₂ Concentration Measurements in the Downstream Plane on Airfoil 1 to 4 And Comparison Between Measured and Assumed Distributions Based on Total Pressure Loss Profiles

On the right side of Figure 8 the measured profiles are compared with the approximated profiles according to the approach “2” (hollow symbols) which are added for the two extreme injection rates (highest and lowest m_c/m_g respectively). It is apparent that the measured coolant distributions are generally much larger than the approximated ones, and contrary to these, not symmetric with respect to the wake core. The coolant is carried further away from the airfoil surface by mixing than the total-pressure loss profiles would suggest. It might be added here that even though the concentrations were measured, the mixing does still not represent a

real engine situation: Cooling air, injected at engine-typical temperature ratios, would not only mix out with the mainflow as it does CO_2 , but would also undergo considerable expansion when adapting to the main flow temperature. This effect could not be simulated with foreign gas injection.

Altering non-symmetry of the measured profiles indicate the varying percentages of coolant exiting from the individual injection rows as injection rate rises. This effect has already been illustrated in chapter 6.3 with the full coverage airfoil 4.

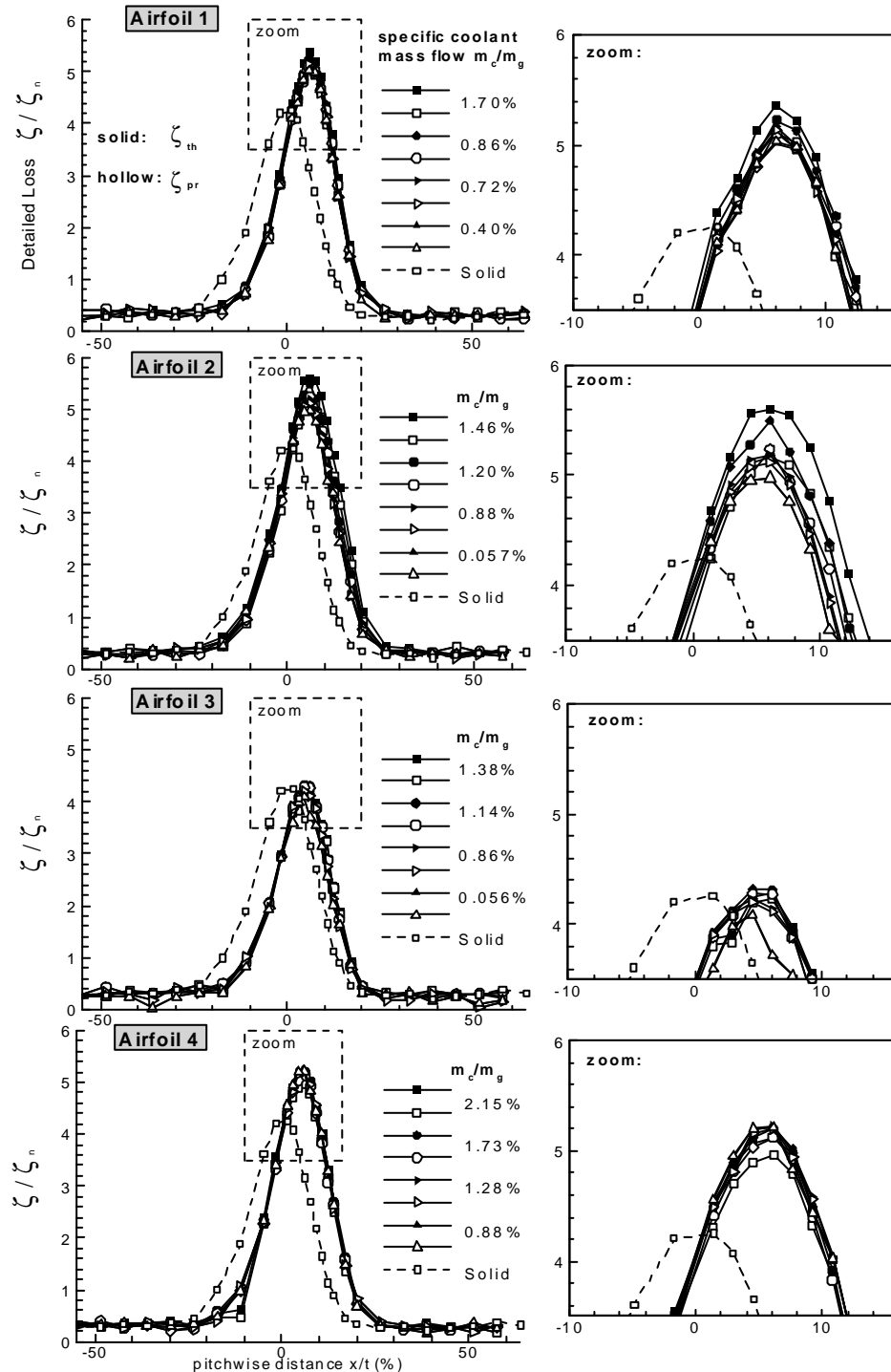


Figure 9 – Detailed Aerodynamic Losses with Film Cooling

SYSTEMATIC LOSS INVESTIGATIONS WITH FILM COOLING INJECTION

The aim of this investigation was to evaluate the aerodynamic performance aspect of shaped holes for film cooling and to compare them with the uncooled airfoil. In this section, both primary and thermodynamic loss results, based on the evaluation method developed above, are presented and discussed (i.e. using real concentration readings, and accounting for the influence of the probe head). Figure 9 shows detailed results, normalized with the mass-averaged primary loss coefficient of the uncooled airfoil, at nominal operating conditions. Solid symbols refer to thermodynamic, hollow symbols to primary loss. In all plots the solid airfoil loss profile is drawn as well.

A common feature for all airfoils is that the location of the wake core is shifted towards the ss, with respect to the loss profiles of the solid model. The wake location is independent of the injection ratios. This shows that the film cooled models have less turning of the main flow, compared to the solid blade. The differences to the nominal outflow flow angle were very similar for all cooled models, and independent of the injection rate, at a value of -1.8° . Small variations were of the same order of magnitude as the measurement uncertainty for the flow angle ($\pm 0.5^\circ$).

Thermodynamic losses are generally slightly higher than primary losses. The dependency on the injection ratio is weak, but noticeable in the zoomed-in view of the wake center (see on the right of Figure 9). The strongest effect of increasing coolant injection was measured on airfoil 2. All but airfoil 3 (leading edge cooling scheme with slots and holes) exhibit higher peak losses in the wake. Airfoil 3 shows peak losses that are comparable to the uncooled model.

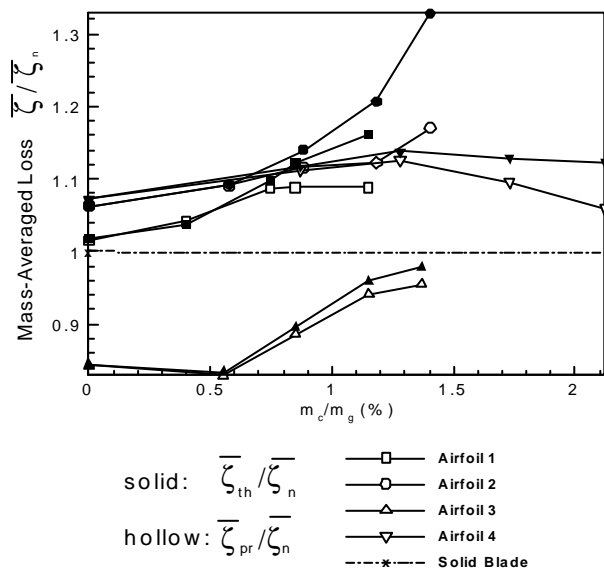


Figure 10 – Comparison of Cooling Configurations in Terms of Mass-Averaged Loss Coefficients as a Function of Injection Ratio

On the basis of the detailed loss profiles a quantitative comparison of the airfoil models in terms of loss increase due to injection is not possible – the obtained differences are too small. The results are therefore discussed as mass-averaged losses \bar{z}/\bar{z}_n , in Figure 10 (again normalized with the mass-averaged solid blade loss at nominal operating point \bar{z}_n).

At zero blowing, \bar{z}_{th}/\bar{z}_n and \bar{z}_{pr}/\bar{z}_n for a specific airfoil configuration are identical. Both primary and thermodynamic losses are a function of injection rate, and generally the thermodynamic loss is higher than the primary loss. The overall level, however, and also the strength of the dependency on the injection rate, are quite different from one model to another:

The highest loss increase were detected for airfoil 2 (ps&ss injection with shaped holes). This configuration has also the strongest dependency on the blowing rate. The mass-averaged thermodynamic loss coefficient is about 30% higher than the solid airfoil nominal value \bar{z}_n , and the primary loss is about 15% higher than \bar{z}_n .

Airfoil 1 (ps&ss injection the cylindrical holes) caused lower levels of loss increase (18%, respectively 10% loss increase), but showed a behavior qualitatively similar to airfoil 1.

A behavior qualitatively similar to airfoil 1 and 2 was previously reported by Drost and Böls (1999), who studied an airfoil model with full coverage cooling, comparable to airfoil 4, and who used the same loss definition as the present study. However, the very high levels of loss increase which were reported in this study (up to 100%) cannot be confirmed with the present results.

The full coverage configuration, airfoil 4, exhibits a loss increase with respect to the solid airfoil of the order of 8% to 15%, which was only weakly dependent of the injection rate. For this model, even a very slight decrease of both loss coefficients was measured. This might be explained with additional energy being added by such strong injection.

Contrary to all other configurations, airfoil 3 (leading edge cooling) decreased loss coefficients by 15% with respect to the solid airfoil case at weak injection. As injection gets stronger, however, the difference becomes smaller, and at highest injection conditions it yields a value very close to solid airfoil case.

CONCLUSIONS

- The determination of aerodynamic loss with film cooling is experimentally difficult. Different loss formulations exist in the literature, and conclusions concerning the effect of cooling on loss depend very much on the definition of loss chosen.
- In the present work, losses were determined based on measurements with a pneumatic 5-hole probe. The presence of the probe was shown to have an influence on the flowfield through a blockage effect caused by the probe shaft. This could be partly accounted for by an adequate measurement procedure, which limited the error on the loss results.
- The local coolant concentration in the downstream plane plays an important role for the determination of thermodynamic loss. The overall level of coolant concentration showed to be critical in order to obtain correct results. The shape of the concentration profile in the pitchwise direction, however, had not much effect on the final result, and can be approximated by the total-pressure loss profile.
- In case of foreign gas injection, the correct overall concentration level can be established with local concentration measurements. If these are not available, the coolant concentration can be approximated. However, the spanwise diffusion needs to be considered.
- The cooling injection generally reduced turning of the cascade by a constant angle of approximately 1.8° .
- The effect of coolant injection on cascade loss depends very much on the actual cooling configuration: The here tested ps and ss configurations yielded loss increase of up to 30% for shaped holes, and 15% for cylindrical holes. The full coverage configuration only increased loss by approximately 10%,

which was almost independent of injection ratio. Leading edge injection reduced cascade loss by 15%, with respect to the solid airfoil.

ACKNOWLEDGEMENTS

This study was carried out within the Brite-Euram 4th framework (contract number BRPR-CT97-0519). The authors would like to thank the Swiss Ministry for Education and Science (BBW) for funding, and the partners of the Brite-Euram consortium for their permission for publication.

REFERENCES

- Day, C.R.B., Oldfield, M.L.G. and Lock, G.D., 1997:** The Influence of Film-Cooling on the Efficiency of an Annular Nozzle Guide Vane Cascade. *ASME, IGTA, Orlando, Florida, Paper 97-GT-521*
- Denton, J., 1993:** Loss Mechanisms in Turbomachinery. *Journal of Turbomachinery, Vol.115, pp 621-656*
- Drost, U. and Böles, A., 1999:** Performance of a Turbine Airfoil with Multiple Film Cooling Stations Part II: Aerodynamic Losses. *ASME, International Gas Turbine & Aeroengine Congress & Exhibition, Indianapolis, Indiana, USA, Paper 99-GT-42*
- Kapteijn, C., Amecke, J. and Michelassi, V., 1996:** Aerodynamic Performance of a Transonic Turbine Guide Vane With Trailing Edge Coolant Ejection: Part I - Experimental Approach. *Journal of Turbomachinery, Vol.118, July 1996, pp 519-528*
- Kollen, O. and Koschel, W., 1985:** Effect of Film Cooling on the Aerodynamic Performance of a Turbine Cascade. *AGARD, Vol.39, pp Paper 39*
- Lakshminarayana, B., 1996:** Fluid Dynamics and Heat Transfer of Turbomachinery, *John Wiley & Sons, Inc., New York*
- Osnaghi, C., Perdichizzi, A., Savini, M., Harasgama, P. and Lutum, E., 1997:** The Influence of Film-Cooling On The Aerodynamic Performance Of A Turbine Nozzle Guide Vane. *ASME, IGTA, Orlando, Florida, Paper 97-GT-522*
- Sieverding, C.H., Arts, T., Dénos, R. and Martelli, F., 1996:** Investigation of the Flow Field Downstream of a Turbine Trailing Edge Cooled Nozzle Guide Vane. *ASME Transactions, Journal of Turbomachinery, Vol.118, April 1996, pp 291-300*