

DEVELOPMENT OF AN ADDITIVE MANUFACTURED MINIATURIZED WEDGE PROBE OPTIMIZED FOR 2D TRANSONIC WAKE FLOW MEASUREMENTS

M. Boerner, R. Niehuis

Institute of Jet Propulsion
Bundeswehr University Munich
Neubiberg, Germany

Keywords: pressure probe, transonic flow, additive manufacture

ABSTRACT

Transonic measurements are known as challenging and several requirements and constraints arising in this flow regime. To meet these challenges, a new Multi-Hole-Probe (MHP) was developed and the design process is described in this paper. The final Miniaturized Wedge Probe (MWP) is particularly optimized for two-dimensional transonic turbine wake flow measurement.

With several references to literature on pneumatic probe design and transonic flow phenomena, this paper is intended to give advice to other researchers facing similar issues, particularly in designing additive manufactured parts. Therefore, special attention is paid to the Direct Metal Laser Sintering (DMLS) process and the requirements to design and manufacturing.

Finally, the MWP was calibrated for high subsonic and low supersonic Mach numbers and different pitch angles at low ambient pressure conditions. From the analysis of the calibration characteristics, the improvements of the probe as well as using base pressure taps for static pressure reference in the flow are demonstrated. Furthermore, the advantages over conventional designs are highlighted.

NOMENCLATURE

Symbols

k_{Ma}, k_α Non-dimensional probe parameter
 Ma Mach number
 p pressure

Subscripts

0 ... 4 Labeling of the probe pressure taps
 bp Base pressure
 t Total conditions
 wf Wedge face

Abbreviations

AM Additive Manufacturing
DLR German Aerospace Center
DMLS Direct Metal Laser Sintering
EDD Electrical Discharge Drilling
HGK High-Speed Cascade Wind Tunnel
MHP Multi-Hole-Probe

MWP Miniaturized Wedge Probe
PIV Particle Image Velocimetry

INTRODUCTION

For measuring in complex 2- and 3-dimensional flow, Multi-Hole-Probes (MHP) are well suited and generally established since many decades. The importance of this measurement technique is still very high, especially related to turbomachinery. According to Grimshaw and Taylor [13] almost 25% of the papers submitted to the Turbomachinery Committee of the ASME Turbo Expo 2015 involve measurement data from pneumatic MHPs. Recently, several publications are related to minimizing the dimension of the probes [13,15,19] in order to reduce blockage effects and facing the challenges of pressure gradients in the flow. Therefore, new manufacturing techniques like Additive Manufacturing (AM) are well suited for manufacturing small and complex components and give much more freedom to the design parameters, for example, on the internal pressure ducts in pneumatic MHPs. In conventional manufacturing of pneumatic probes, the geometry of the internal pressure ducts is strongly restricted because of the use of hypodermic steel tubes and linear manufacturing tools [7,13]. Since the rapid devolvement of new AM methods like Direct Metal Laser Sintering (DMLS) the production of high quality metal products becomes possible. With this method, three-dimensional objects are build up layer wise by fusing metal powder with a focused laser (cf. Figure 1). Therefore, components with complex internal duct structures can be manufactured [2].

A special application for MHP are wake flow measurements downstream of turbomachinery cascades. On this, reliable flow measurements are essential since they are used for the validation of the numerical design process for new engine profiles. Nowadays, transonic turbine profiles are in focus of many research projects closely linked to the benefit of increasing the spool speed in turbomachine applications. A major challenge arises when measuring with pneumatic MHPs in

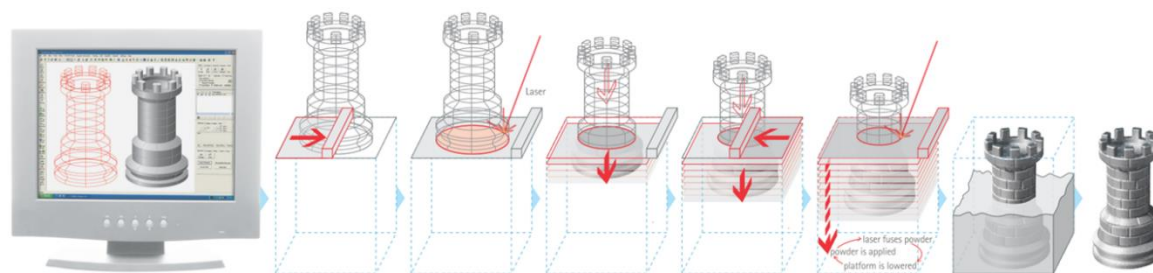

Figure 1: Visualization of the Direct Metal Laser Sintering (DMLS) process [2]

transonic wake flows, because of the existing constraint close to $Ma = 1$ resulting in an insensitivity of determining the flow Mach number and the static pressure respectively [14]. Investigations of Fransson et al. [10] showed, that wedge type probes are most suitable in transonic flow regimes in comparison to blunt probe head geometries with low sensitivity in determining the static pressure close to Mach unity [3,16].

CHALLENGES IN TRANSONIC FLOW

In transonic flows, the highest uncertainties in MHP measurements occur in determining the static pressure or the Mach number, which are closely related to each other [11,17]. For example, Boerner et al. [3] report of an increasing uncertainty by a factor 5 above $Ma = 0.8$ in determining the Mach number in high subsonic flows with a hemispherical Five-Hole-Probe (FHP). This phenomenon was theoretically described by Hancock [14] and experimentally investigated in detail by Kost [16] for different probe types of blunt and sharp head geometries. In theory, all blunt bodies feature the appearance of a detached shock wave in supersonic flows. If the flow Mach number in front of the body is just slightly above Mach 1, a detached shock wave emerges in a distance upstream of it and is roughly normal to the flow direction. The flow downstream of the shock wave is consequently subsonic and the pressure taps at the probe head sensing subsonic conditions, too. If the flow Mach number increases, the shock wave moves closer to the probe head but its orientation to the flow still remains mostly normal. Therefore, the conditions downstream stay subsonic and the pressure taps at the probe head do not sense a significant change. Kost [16] showed that this insensitivity of the pressure distribution on a cylindrical probe can range up to $Ma = 1.3$. On the contrary, it is reported, that sharp probe head geometries feature a less decreasing sensitivity in the transonic flow regime since attached shocks instead of detached shocks appear. This directly results in less uncertainty determining Mach number and static pressure respectively in the flow field at transonic flow speed.

Besides the uncertainties arising from the pressure sensors used during calibration and measurement, the major source of measurement errors are due to the fact that total and static

pressure are not measured at exact the same position in the flow field [17]. This is related to the discrete distance of the pressure taps at the head and leads to increasing measurement errors particularly in flows with high pressure gradients. This can be affirmed by the investigations of Boerner et al. [3]. There, measurements with PIV and a hemispherical Five-Hole-Probe in a transonic turbine wake were conducted. The deviations between pneumatic and optical results were highest in the regions of high pressure gradients and increase as the overall flow Mach number increases, too. Even common known interpolation correction methods between measuring positions [21] could not completely compensate the overestimation by the Five-Hole-Probe. This means, apart from optimizing the probe head shape, a miniaturized probe head size is a major design requirement for developing a new and more reliable MHP.

DESIGN CONCEPT

General probe design

A useful overview on pneumatic probe designs in general is given by Bryer and Pankhurst [7]. Together with the previous findings, a design concept for the new MHP optimized for transonic wake flow measurement was elaborated.

The primary objective of the probe is the determination of the exit flow quantities of transonic turbines cascades at mid span (two-dimensional flow) in the High-Speed Cascade Wind Tunnel (HGK) at the Institute of Jet Propulsion at the Bundeswehr University Munich. There, the cascade wind tunnel is placed inside a pressure tank. In order to obtain engine relevant Reynolds numbers during the test, the ambient pressure can be reduced down to 3.5 kPa . More details on the facility can be found in Sturm and Fottner [18]. At low pressure conditions, the settling time of the probe increases significantly and, therefore, it is important to be considered in the design. This means that, on the one hand, the pressure orifices at the probe head has to be as big as possible and the pressure ducts should expand closely afterwards [13]. On the other hand, the probe dimension should be as small as possible at the same time to minimize the local influence on

the flow field. Therefore, a compromise has to be found.

For minimizing the blockage effect of the probe and its support in general, the best solution is a long sting with the MHP head at the end which is introduced from far behind the cascade [17]. Boerner et al. [3] showed that even at high exit flow Mach numbers close to supersonic flow speed the blockage effect of such an experimental setup is less than 1 % in flow velocity. The effect is small compared to transonic measurements with probes perpendicular to the flow in rotating turbine rigs. There, the blockage effect can influence the dynamic pressure up to 15 % [20].

From a design point of view, the cylindrical shaft and the pressure ports of a sting probe can be easily manufactured from standard steel and hypodermic tubes. On the contrary, the probe head is the more complex part. Hence, a two-part design concept of a separate manufactured probe head and a probe shaft assembly was chosen here.

External probe head geometry

According to the sensitivity investigations of Kost [16], the best probe head geometry for transonic flow measurements has to be sharp edged. Furthermore, it is concluded that so-called base pressure taps located in the wake of the probe head increase the sensitivity of static pressure measurements in the transonic flow region significantly.

On the contrary, it has to be considered, that sharp edges are more sensitive to Reynolds number variations [4], but the investigations on that is limited to individual probe heads and Reynolds number ranges [6]. On the relationship between Reynolds number and the orientation of the pressure orifices, the work of Dominy and Hodson [9] give a good overview on several types of Five-Hole-Probes. They conclude that the probe characteristic are significantly less affected by Reynolds number effects, if the pressure taps are drilled normal to the surface of the probe head compared to forward facing pressure taps.

Considering all the mentioned aspects above, the probe design of Amecke and Lawaczeck [1] at the DLR in 1967 was found to best fulfill the requirements. The probe was kindly provided by the DLR and pre-tests in a freestream showed the promising characteristic of the probe head geometry. However, the dimensions of the probe were supposed to be reduced in order to achieve a better performance particularly in high pressure gradient flow fields of turbine wakes. Figure 2 shows the original probe design and the final design of the new, so-called Miniaturized Wedge Probe (MWP) for size comparison. The diameter of the shaft was halved from 6 mm to 3 mm and the wedge thickness was reduced by approximately 13 %. Furthermore, the used Pitot tube diameter

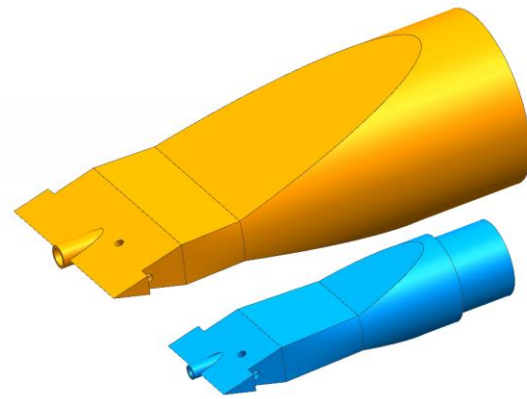

Figure 2. Size comparison of the probe heads from Amecke and Lawaczek [1] (top, shaft diameter 6 mm) and the new Miniaturized Wedge Probe (MWP) (bottom, shaft diameter 3 mm)

for the MWP was reduced by 37.5 % to obtain better spatial resolution referred to total pressure loss measurements [13]. Important to mention, the mouth of the Pitot tube has a small offset from the probe edge, which was already considered at the probe from Amecke to improve the total pressure measurement, particularly, in supersonic flows [1]. The inner to outer diameter ratio of the Pitot tube was maximized for less sensitivity to flow angle misalignment [7].

For the connection between probe head and steel tube of the shaft a plain lathe face is provided at the opposite of the probe head tip. Also, plug-in holes are designated for the hypodermic pressure tubes connection.

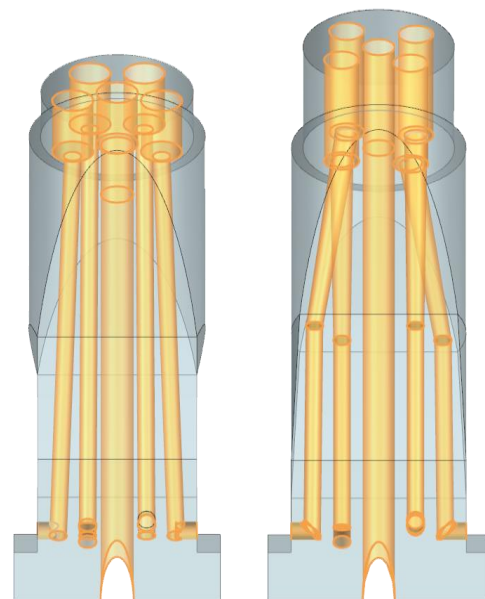

Figure 3: Internal pressure duct design for EDD (left) and AM (right) method

Internal pressure ducts

Obviously, the external dimension of the probe head is closely related to the design of the internal pressure ducts. From experiences with the settling time of several MHPs in the HGK facility at reduced ambient pressure, the pressure orifices on the probe head were intended to be not smaller than 0.3 mm in diameter. This means that the internal ducts has to be at least the same size. Therefore, Electrical Discharge Drilling (EDD) and Direct Metal Laser Sintering (DMLS) were figured out to be qualified for manufacturing internal ducts of the intended dimensions in length and diameter. Based on the intended positions of the pressure orifices at the probe head (cf. Figure 6), the two different internal duct designs in Figure 3 were elaborated.

With EDD only linear ducts can be drilled and the channel length is limited. The duct design is shown in Figure 3 on the left. With a minimum wall thickness of 0.2 mm between the ducts at the probe head tip, it was possible to generate a design, which fulfilled the requirements of the EDD method. Nevertheless, the length of the plug-in holes for the connecting pressure tubes are limited in its length in order to take account of the necessary drilling angle of the EDD tool. Furthermore, the pressure ducts featuring a constant small diameter.

In contrast, the AM offers a lot more flexibility. The first part of the ducts shown in Figure 3 on the right side is of constant diameter of about 0.3 mm . After the visible bend, the probe head geometry expands and so do the pressure ducts. At the plug-in holes the duct has a diameter of about 0.4 mm . Consequently, the smallest cross section of the ducts is kept as short as possible and,

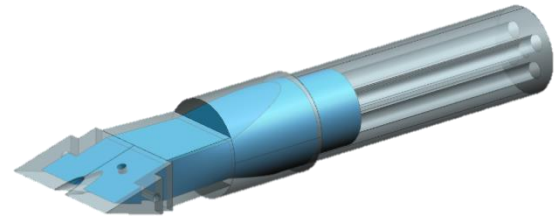

Figure 4. Design of the sintered raw probe head with additional material (grey) to the final MWP head (blue)

therefore, the settling time of the pressure ducts will be reduced [13]. Here, the minimum wall thickness is 0.21 mm in just few regions on the wedge. Furthermore, the plug-in holes can be designed longer for connecting it to $0.6 \times 0.1\text{ mm}$ standard steel tubes.

Overall, the costs for EDD fabrication of the presented geometry is comparable with a high-precision DMLS process. Nevertheless, the production time as well as the expected measurement performance speak in favor of the sintered part, which is why the AM design concept was finally chosen and further promoted.

ADDITIVE MANUFACTURING

Related to the manufacturing process itself, additive manufactured parts requires some special design considerations. On this, Bindl et al. [2] gives a good overview on several important aspects in their work on designing an additive manufactured compressor vane with integrated MHPs. In the case of the MWP head here, it was important to already consider the finishing process of the final sintered

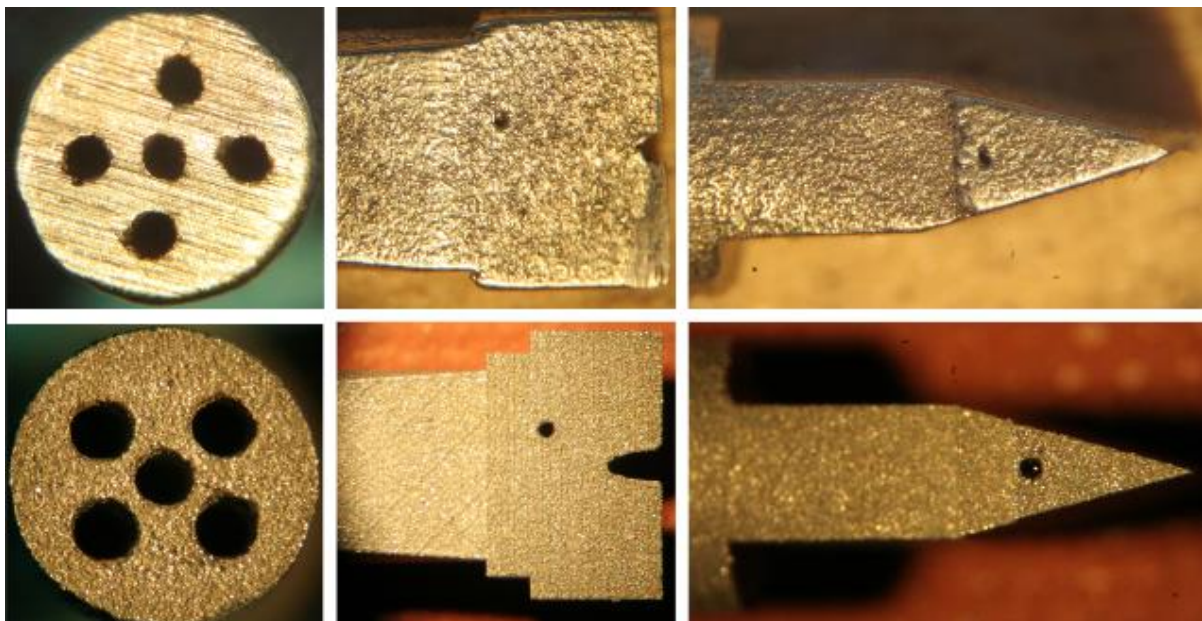

Figure 5: Raw sintered probe head build with a layer thickness of $10 \dots 50\text{ }\mu\text{m}$ (upper row) and with $1 \dots 5\text{ }\mu\text{m}$ (bottom row)

Left: plug-in holes (0.6 mm); center/right: top/side view of wedge with pressure orifices (0.3 mm)

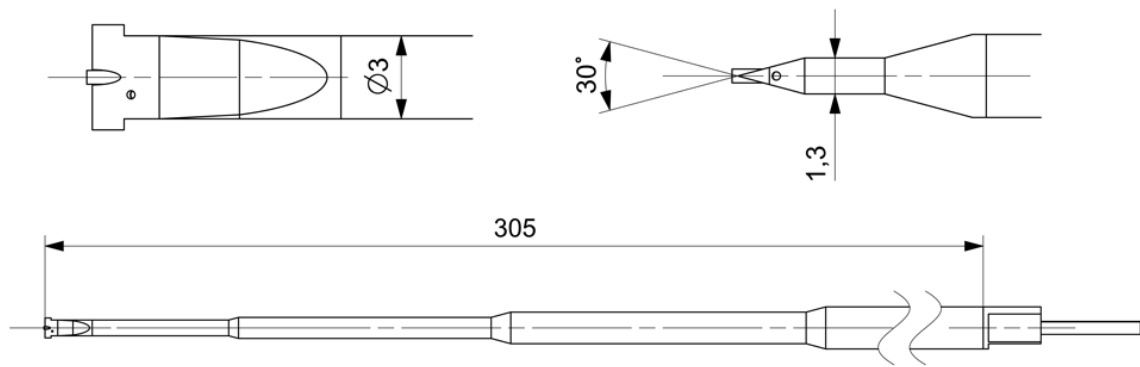

Figure 7: Dimensions of Miniaturized Wedge Probe (MWP) with probe shaft

object. On the one hand, additional material for surface machining has to be provided and, on the other hand, the possibility for mounting the object for the finishing process has to be considered. Figure 4 shows the design of the finally sintered raw part with a material offset of 0.2 mm to the final MWP head in blue. Furthermore, the cylindrical part of the probe head was expanded to mount it on the turning lathe.

Finally, the raw part design was manufactured with two different DMLS machines of different laser focal diameter and add-on layer thicknesses. The used metal powder was stainless austenitic steel 1.4404. Different views of the sintered raw probe head through a microscope are shown in Figure 5. The coarser process was performed on a *TruPrint 1000* with a laser focal diameter of $55\ \mu\text{m}$ and a layer thickness of $50\ \mu\text{m}$ (top row). There, the particle size was $60\ \mu\text{m}$. For the finer one, a *DMP50 GP* was used. There, the laser was focused on a just slightly smaller diameter of approximately $30\ \mu\text{m}$. But the layer thickness was a tenth of the former machine and the particle size was just $5\ \mu\text{m}$. The result is depicted in the bottom row of Figure 5. The influence of the different layer thicknesses on the surface roughness is obviously visible. The pressure orifices of 0.3 mm on the wedge faces of the coarser part (top center and top right) are difficult to identify and the plug-in holes, which are intended to have a diameter of 0.6 mm , are obviously smaller and deformed (top left). On the contrary, the plug-in holes and also the pressure orifices on the wedge face in the finer part are clearly well defined. This implies that the internal pressure ducts feature the same surface roughness as the outer part. But even for the coarser part the ducts were not blocked which was tested with compressed air in a water bath. Nevertheless, the test shows that the pressure ducts of the coarser part were obviously smaller than intended. On the contrary, the more high-precision manufacturing process proves satisfying results and the finishing process was applied to this part. Of course, the fabrications with smaller layer thickness is more

time consuming. In this case, the finer part take seven times longer and, therefore, the production cost increases by approximately one order of magnitude for a single part. Nevertheless, compared to conventional manufacturing processes, the sintering process is much faster and with the rapid development and distribution of AM machines it is also more suitable for small batch series or prototypes, as they usually occur for research purposes.

Finally, the finished probe head was assembled. A drawing is displayed in Figure 7. For the Pitot tube, a steel tube was stuck through the probe head and fixed with its mouth slightly in front of the wedge edge. Furthermore, the inner edge of the Pitot mouth was chamfered to obtain as less flow angle sensitivity as possible. For the four remaining pressure ducts, steel tubes of $0.6 \times 0.1\text{ mm}$ diameter were used and connected to the above mentioned plug-in holes. The shaft was assembled in four stages with standard steel tubes, either.

CALIBRATION AND PERFORMANCE

The MWP was calibrated for Mach numbers between 0.5 and 1.6 and pitch angles of $\pm 16^\circ$ at the Wind Tunnel for Probe Calibration (SEG) from the Institute of Propulsion Technology at the German Aerospace Center (DLR) in Göttingen. The test section as well as the whole closed wind tunnel loop system can be evacuated. Further details of the facility can be found in Gieß et al. [12].

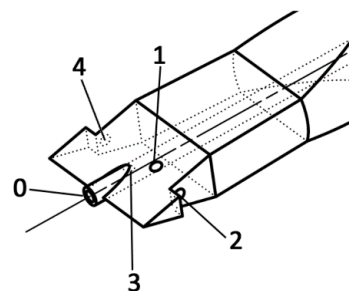

Figure 6: Positions and labeling of the pressure taps at the MWP head

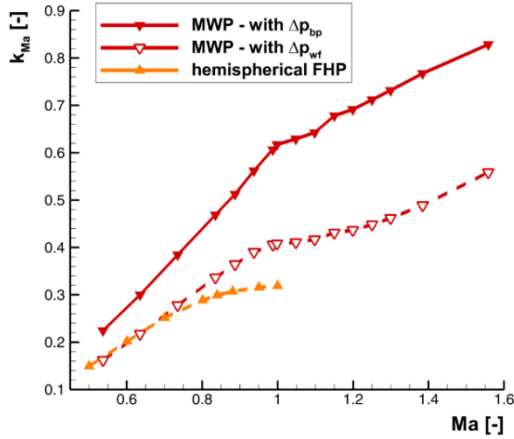

Figure 8: Mach number parameter at zero incidence

Since the probe is intended to be used in low ambient pressure environment during the measurements, the calibration was performed at the lowest possible ambient pressure of 12 kPa. This resulted in Reynolds numbers based on the wedge thickness (1.3 mm) between $1.8 \cdot 10^3$ and $9.3 \cdot 10^3$.

For evaluating the measured pressure from the probe, the data reduction method according to Bohn and Simon [5] is used. From the five pressure taps at the probe head (cf. labeling in Figure 6), the non-dimensional probe parameter can be derived. They are closely connected with its special flow quantity Mach number and pitch flow angle, respectively:

$$k_{Ma} = \frac{\Delta p}{p_0} \quad (1)$$

$$k_\alpha = \frac{p_3 - p_1}{\Delta p} \quad (2)$$

Therein Δp is the quantity related to the dynamic pressure of the flow. Either, it can be derived with the pressure from the wedge face (wf)

$$\Delta p_{wf} = p_0 - \frac{p_1 + p_3}{2} \quad (3)$$

or with the base pressure (bp) taps

$$\Delta p_{bp} = p_0 - \frac{p_2 + p_4}{2}. \quad (4)$$

The advantages of using the base pressure taps for referencing the dynamic pressure can be seen in the characteristic of the Mach number parameter k_{Ma} plotted over the Mach number at zero flow incidence in Figure 8 (red lines). Obviously, the slope of the solid line is generally steeper compared to the red dashed one. But more important, the characteristic based on the base pressure does not flatten in the high subsonic region close to Mach unity and just slightly decreases in the supersonic flow region. Both Boerner et al. [3] and Kost [16] showed, that the

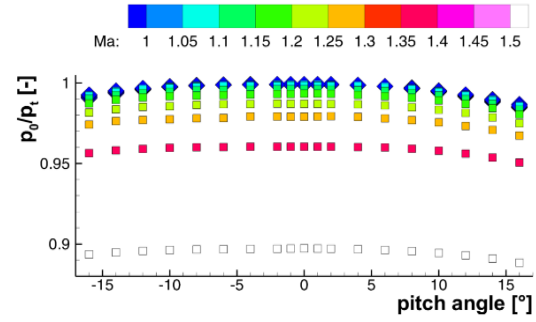

Figure 10: Flow angle sensitivity of total pressure measurement for all calibrated flow Mach numbers. Measurements values of subsonic flow (blue diamonds) are close together

slope of the k_{Ma} characteristic is directly related to the measurement uncertainty. If the slope of the characteristic decreases, the measurement error of its quantity is increasing simultaneously. This means that high improvements in measuring the Mach number and static pressure respectively of transonic flows could be achieved by applying the base pressure ports to the probe.

Furthermore, Figure 8 shows the characteristic of a Five-Hole-Probe with hemispherical probe head (orange dashed line). There, the slope decreases already at $Ma = 0.8$ and a pronounced plateau is reached towards sonic flow speed. Based on the investigation of Kost [16] it can be expected, that the slope of the characteristic is barely increasing above Mach 1. This further enhances why sharp instead of blunt probe head geometries are preferable in the transonic flow regime.

As expected, the pressure measurements with the Pitot tube p_0 of the probe in subsonic flow agree very well with the total pressure in the flow at zero incidence. In supersonic flow, p_0 matches the theoretical total pressure ratio downstream and upstream of a normal shock, which is depicted in Figure 9. Through the already mentioned high ratio of inner and outer diameter of the used Pitot tube, the total pressure measurement are less affected by pitch angle variations (cf. Figure 10). All subsonic measurement (blue diamonds) lying above each other, showing similar flow angle dependency. For pitch angles of $\pm 10^\circ$ the pressure reading of p_0 is less than 1 % erroneous to the real total pressure of the flow. In the supersonic flow regime the shape of the plots are alike the subsonic ones but the shock losses is clearly observable. Nevertheless, the deviation of the pressure readings of p_0 is similar less affected by flow incidence angles in supersonic

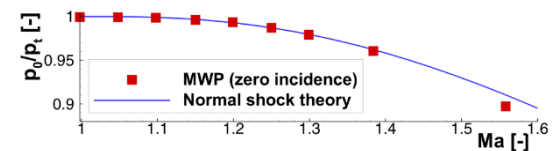

Figure 9: Total pressure measurement in supersonic flow at zero incidence compared to normal shock theory

flow regimes. Since the Mach number parameter k_{Ma} of the MWP measurement indicates whether subsonic or supersonic flow is present, the actual total pressure of the flow can be uniquely assigned to the measured p_0 .

Furthermore, an incidence angles in yaw direction between $\pm 2^\circ$ as negligible effects on the measurements of the MWP, which was tested for all Mach numbers and pitch angles. Therefore, the MWP is well suited for real profile loss measurements and obtaining exit flow quantities in turbine cascade applications particularly in transonic exit flow conditions.

To complete the picture, it has to be stated, that the characteristic of the pitch angle parameter shows an approximately linear trend. This is displayed in Figure 11 for three different Mach numbers. It can clearly be seen that the characteristic is almost independent of the flow Mach number and the slope is almost constant over the entire calibrated pitch angle range.

SUMMARY & OUTLOOK

The development process of a new Multi-Hole-Probe (MHP) for applications in transonic flows was described. Therefore, the challenges arising when measuring in transonic flows were pointed out and the pre-investigations are summarized. Based on the conclusions, the design of an already existing probe was adopted and miniaturized. Special attention was paid to the design of internal pressure ducts. There, additive manufacturing like DMLS gives much more freedom to the orientation, shape, and size adaption of the ducts, which is why this method was chosen. Nevertheless, the developer needs profound knowledge on the technology and particular issues have to be considered.

The final probe was assembled from the sintered probe head and standard steel tubes for the shaft. Afterwards, the probe was calibrated for high subsonic and low supersonic Mach numbers at low ambient pressure conditions. The calibration characteristics shows the improvement of the probe design, particularly compared to blunt probe head shapes in the transonic flow regime. First measurements in the High-Speed Cascade Wind Tunnel demonstrated these improvements, already. It turns out that, the MWP is very well suited for transonic flow measurements especially in determining the real profile losses and exit flow quantities in turbine cascade applications at mid span, where two-dimensional flow can be assumed.

However, the direct interaction of the probe head with shock waves in the flow should be avoided. Dietrichs et al. [8] showed for the Amecke probe with the same design as the MWP, that even with time-consuming correction methods the total losses of the shock were not correctly evaluated.

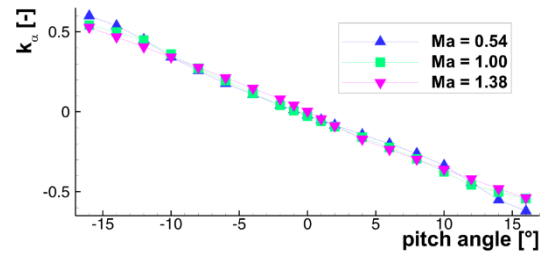

Figure 11: Characteristic of the pitch angle parameter k_α for three different Mach numbers

Visualization with Schlieren can be used to check for these possible interaction.

In order to validate the flow measurement results from the MWP, a comparison with a second, independent measuring technique like PIV is projected. Furthermore, measurements with the probe at different ambient pressure conditions should be performed to check for possible Reynolds number effects arising from the sharp edges of the probe head and to define the operating range of the conducted calibration.

ACKNOWLEDGMENTS

The research leading to this paper was based on an AG Turbo project in cooperation with the MTU Aero Engines AG. The authors would like to thank MTU for the cooperation and support in the development process of the new probe. Special thanks goes to Jürgen Rehder from the DLR Göttingen for providing the probe designed by Amecke for pre-investigations. Furthermore, the authors would like to thank Katharina Kreitz and her team from VectoFlow for bringing in their expertise on the DMLS process and the really good collaboration. Last but not least, thank goes to Wolfgang Lorz for his great support in assembling the MWP to its final design.

REFERENCES

- [1] Amecke, J.; Lawaczeck, O.; 1968. "Aufbau und Eichung einer neuentwickelten Keilsonde für ebene Nachlaufmessungen, insbesondere im transsonischen Geschwindigkeitsbereich". Neue Ausführung der Sonde, Göttingen.
- [2] Bindl, S.; Kern, F.; Niehuis, R.; 2017. "Additive Manufacturing of a Compressor Vane with Multi-Hole Pressure Probes". In: XXIII. International Symposium on Air Breathing Engines (ISABE). Manchester, England.
- [3] Boerner, M.; Bitter, M.; Niehuis, R.; 2018. "On the Challenge of Five-Hole-Probe Measurements at High Subsonic Mach Numbers in the Wake of Transonic Turbine Cascades". In: Proceedings of the Global Power and Propulsion Society Conference 2018. Montréal, Canada.

- [4] Bohn, D.; 1977. "Untersuchung zweier verschiedener axialer Überschallverdichterstufen unter besonderer Berücksichtigung der Wechselwirkungen zwischen Lauf- und Leitrad". Dissertation, Aachen.
- [5] Bohn, D.; Simon, H.; 1975. "Mehrparametrische Approximation der Eichräume und Eichflächen von Unterschall- bzw. Überschall-5-Loch-Sonden. tm - Technisches Messen.
- [6] Broichhausen, K.-D.; Kauke, G.; 1981. "Investigation of the Reynolds-number effects on probe measurements in supersonic flow. In: 6th Symposium on Measurement Techniques in Transonic and Supersonic Flows in Cascades and Turbomachinery". Lyon, France.
- [7] Bryer, D. W.; Pankhurst, R. C.; (1971) "Pressure-probe methods for determining wind speed and flow direction". Her Majesty's Stationery Office, London.
- [8] Dietrichs, H.-J.; Hourmouziadis, J.; Malzacher, F.; Bräunling, W. J. G.; 1987. "Flow Phenomena in transonic turbines cascades. Detailed experimental and numerical investigation". In: 8th International Conference of Air Breathing Engines (ISABE), Cincinnati, Ohio.
- [9] Dominy, R. G.; Hodson, H. P.; 1993. "An Investigation of Factors Influencing the Calibration of Five-Hole Probes for Three-Dimensional Flow Measurements". *J. Turbomach.* 115, 513–519.
- [10] Fransson, T.; Sari, O.; 1981. "Characteristics of Aerodynamic Five-Hole-Probes in Transonic and Supersonic Flow regimes". In: 6th Symposium on Measurement Techniques in Transonic and Supersonic Flows in Cascades and Turbomachinery. Lyon, France.
- [11] Fransson, T.; Schaller, F.; Schulz, K.; 1988. "Change of Flow Conditions due to the Introduction of an Aerodynamic Probe during Calibration". In: 9th Symposium on Measuring Techniques in Transonic and Supersonic Flow in Cascades and Turbomachines. Oxford, UK.
- [12] Gieß, P.-A.; Rehder, H.-J.; Kost, F.; 2000. "A New Test Facility for Probe Calibration - Offering Independent Variation of Mach and Reynolds Number". In: 15th Symposium on Measuring Techniques in Transonic and Supersonic Flows in Cascades and Turbomachines. Florence, Italy.
- [13] Grimshaw, S.D.; Taylor, J.; V.; 2016. "Fast settling millimetre-scale Five-Hole-probe". In: ASME Turbo Expo 2016: Turbomachinery Technical Conference and Exposition. Seoul, South Korea.
- [14] Hancock, P. E.; 1988. "A Theoretical Constraint at $M=1$ for Intrusive Probes and Some Transonic Calibrations of Simple Static-Pressure and Flow-Direction Probes". In: 9th Symposium on Measuring Techniques in Transonic and Supersonic Flow in Cascades and Turbomachines. Oxford, UK.
- [15] Hoenen, H.T.; 2015. "Development of a Miniaturized Pneumatic Multi-hole Probe for Turbomachinery Measurements". In: International Gas Turbine Congress 2015 (IGTC2015). Tokyo, Japan, pp. 1504–1511.
- [16] Kost, F.; 2009. "The behaviour of probes in transonic flow fields of turbomachinery". In: 8th European Conference on Turbomachinery (ETC). Graz, Austria.
- [17] Sieverding, C. H.; 1993. "Subsonic-Choked (Turbine) Cascades. In: Hirsch, C. (Ed.), Advanced methods for cascade testing", NATO AGARD, Neuilly sur Seine, pp. 22–34.
- [18] Sturm, W.; Fottner, L.; 1985. "The High-Speed Cascade Wind-Tunnel of the German Armed Forces University Munich". In: 8th Symposium on Measuring Techniques for Transonic and Supersonic Flows in Cascades and Turbomachines. Genua, Italy.
- [19] Town, J.; Camci, C.; 2011. "Sub-Miniature Five-Hole Probe Calibration Using a Time Efficient Pitch and Yaw Mechanism and Accuracy Improvements". In: ASME Turbo Expo 2011: Turbine Technical Conference and Exposition, ASME. Vancouver, British Columbia, Canada, pp. 349–359.
- [20] Truckenmüller, F.; Stetter, H.; 1996. "Measurement errors with pneumatic probes behind guide vanes in transonic flow-fields". In: 13th Symposium on Measuring Techniques for Transonic and Supersonic Flow in Cascades and Turbomachines. Zürich, Switzerland.
- [21] Vinnemeier, F.; Simon, L.; Koschel, W.; 1990. "Korrektur des Kopfgeometrieinflusses einer Fünfloch- Drucksonde auf die Meßergebnisse". tm - Technisches Messen 57.